



Control Panel

The gen-set control panel was designed to include, in one single panel, the switches, control devices and the protection devices. The components are the following :

- Engine cut-off module for automatic stop of engine in case of high water temperature, low oil pressure, high alternator temperature.
- Hour-meter.
- Start-stop button.
- Breaker for protection against of overload or short circuit.
- Thermal switch.

Engine

- Easy access in case of maintenance to the feeding system and lubrication, of the sea/water pump and the air filter.
- Safety stop in case of low oil pressure.
- Safety stop in case high water/exhaust gas temperature.
- Double vibration dumping system.
- Oil and fuel filters of easy access.
- Oil drain pump.

Alternator

- Synchronous, 4 poles, brush less self-excited, electronic voltage regulator (AVR).
- Rotor and stator epoxy resin coated against external agents.
- Rotor dynamically balanced.
- Insulation class H.

Soundproof cabin

A new project engineering design with a structure of a draw piece of aluminum supporting, painted aluminum panels type 5754 of high resistance to external agents.

Of limited weight and easy accessibility to the inner cabin in case of maintenance services.

THE INTERCOOLER W/A

Assures the perfect functioning of the generator independently of the external ambient temperature, therefore the alternator and the engine will work at ideal temperature optimizing the performance and reliability of the gen-set.

Engine	50 Hz	60Hz
Model	Yanmar 3TNE82	
Type	Diesel 4 stroke	
Cylinders (nr.)	3	
Cylinder block material	Cast iron	
Bore (mm. - in.)	82 - 3.2	
Stroke (mm.- in.)	84 - 3.4	
Displacement (cc. - CID)	1331 - 89.8	
Power (hp)	14.8	17.8
RPM	1500	1800
Compression ratio	18:1	
Combustion system	Direct injection	
Engine head material	Cast iron	
Speed governor	Centrifugal mechanical	
Lubrication system	Forced	
Oil sump capacity with filter(l -gl)	5.2 - 1.2	
Engine stop system	Stop solenoid	
Fuel pump	Electric	
Fuel pump discharge (cm. - ft)	70 - 2.3	
Fuel consumption (l/h - gl/h)	3.2 - 0.7	3.6 - 0.75
Air intake (l/min. - gl/min.)	790 - 173	948 - 208
Starting battery (Ah-V)	70 - 12	
Battery charger (Ah-V)	40 - 12	
Starter (kW-V)	1.2 - 12	
Max. inclination	30°	
Water pump flow (l/min. - gl/min.)	25 - 6.6	28 - 6.1

Alternator	50 Hz	60Hz
Type	Synchronous, 4-poles, brush less self-excited	
Regulation	Electronic	
Cooling	Air/water (Intercooler W/A)	
Voltage (V)	115 - 230	120 - 240
Frequency (Hz)	50	60
Amps	78.2 - 39.1	83.3 - 41.6
Max. power (kW)	9	10
Continuous power (kW)	8.2	9.5
Power factor (cos ø)	1	
Insulating class	H	
Voltage stability	±2%	
Frequency stability	±5%	

Cooling system

The cooling of the engine is based on a closed inner flow of coolant.

The system is based on a heat exchanger seawater/coolant type, of cupronickel, where the thermal exchange occurs between the two liquids.

Two separate pumps contribute to the flow of the coolant and the sea water. The cooling of the air inside the gen-set is obtained through a seawater/air heat exchanger. This provides the efficacious cooling of the alternator and the optimal temperature for the best performance and reliability of the gen-set despite its on board allocation and room temperature.

	50 Hz	60Hz
Dimension (Lenght x Width x Height.)	837x568x688mm - 32.95x22x27.08 (in.) (with soundproof box)	
Weight	295 Kg. - 555 (lb) (with soundproof box)	
Noise Level	49 dB _A at 7mt (23 ft)	51 dB _A at 7mt (23 ft)

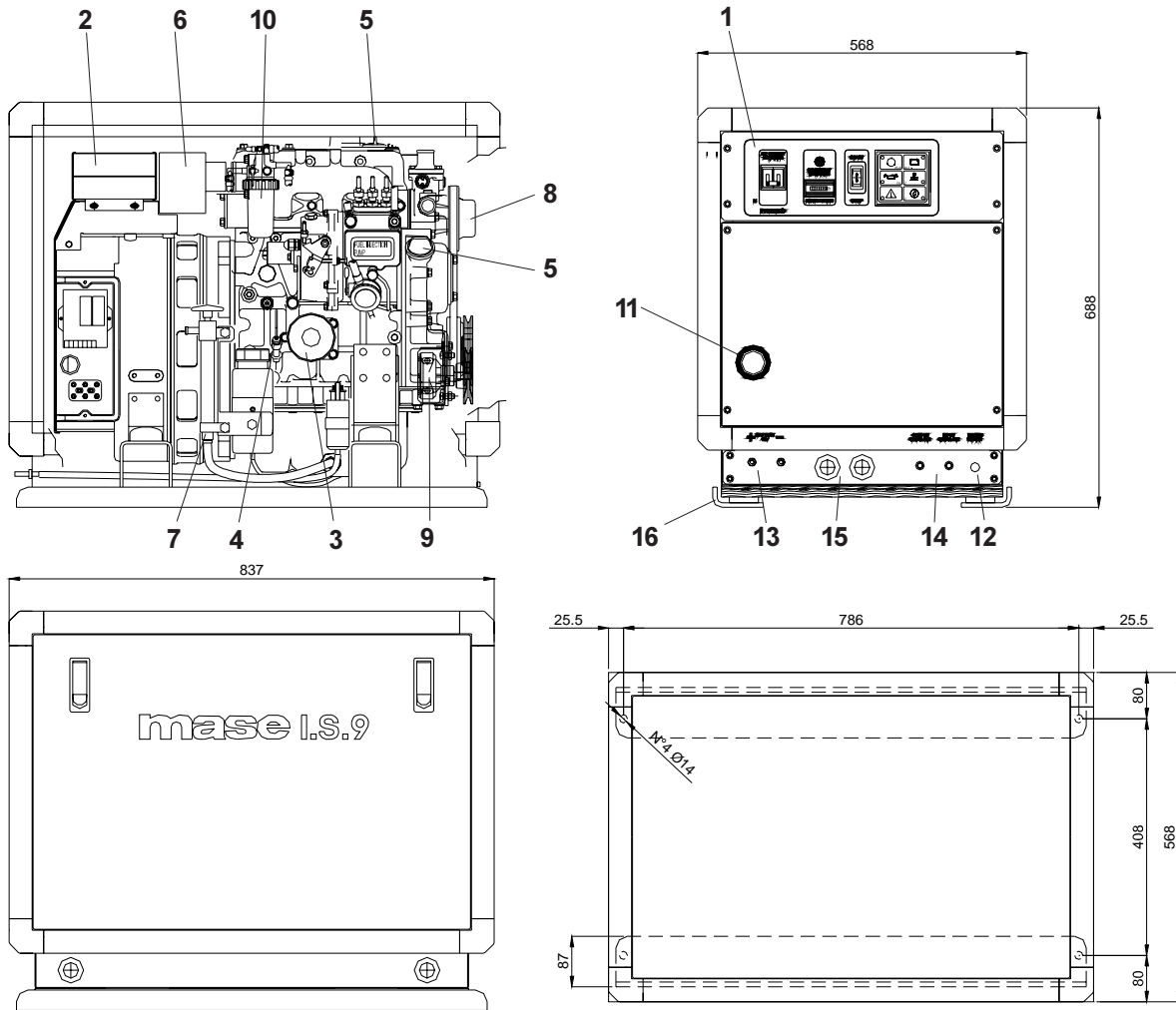

- | | |
|--------------------------|------------------------------------|
| 1- Control panel | 9 - Sea water pump |
| 2- Air / water exchanger | 10 - Fuel filter |
| 3 - Oil filter cartridge | 11 - Exhaust manifold (ø 50mm) |
| 4 - Oil dipstick | 12 - Sea water intake (ø 16mm) |
| 5 - Engine oil filler | 13 - Battery connections |
| 6 - Air filter | 14 - Fuel tank connections (ø 8mm) |
| 7 - Oil drump pump | 15 - Cable outlets |
| 8 - Fresh water pump | 16 - Genset base brackets |

FITTINGS

EXHAUST COMPONENTS KIT

SIPHON BREAK

W.G. SEPARATOR KIT

REMOTE CONTROL PANEL COMPLETED OF INSTRUMENTS

*This drawing is only a reference and is indicatly for the installation. For more information, you may contact your local dealer or **mase generators S.p.A.***

***mase generators S.p.A.** reserves the right to change the design or specifications without notice and without any obligations or liability whatsoever. For more information, you may contact your local **mase** dealer.*

Allocation:

mase
MARINE

MASE GENERATORS S.p.A. Via Tortona, 345
47023 Cesena (FC) Italy
Tel.+39-0547-354311 Fax.+39-0547-317555
Email : mase@masegenerators.com
www : masegenerators.com